

High Output Boiler Systems

Information for Dual System Link up methods

For use in GB & IE (Great Britain and Republic of Ireland).

This appliance has been certified for use in countries other than those stated. To install this appliance in these countries, it is essential to obtain the translated instructions and in some cases the appliance will require modification. Contact Redfyre for further information.

IMPORTANT

This appliance will become hot whilst in operation, it is therefore recommended that a suitable guard should be used for the protection of young children, the elderly or infirm. Do not attempt to burn rubbish in this appliance.

Please read these Instructions carefully before installation or use.
Keep them in a safe place for future reference and when servicing the fire.

The commissioning sheet found on page 3 of these instructions should be completed by the Installer.

CONTENTS

GENERAL INFORMATION	3
Introduction	3
Dual fuel 'link up' pipe work systems	3
Common faults when designing and fitting a link up system	3
HEATING SYSTEM	5
General	5
Refyre Solid Fuel Boiler	5
Boiler Sizing	5
Hot Water Cylinder	5
Open Vent and Cold Feed system	5
Heat Leak Radiator	5
Pump	6
Electrical Supply	6
Pipe work systems	6
Gravity pipe circuit	6
DIAGRAMS	7
Open system pipe work layout	7
Open system controls	8
Open system pipe work and controls layout	9
Solar system pipe work and controls layout	10
Sealed system pipe work layout	11
Sealed system controls	12
Propriety devices	13
CONTROLS	15
General Heating System Controls	15
Controls for link systems	15
Pump assisted central heating	17
Fully pumped system	17
Sealed (Pressurized) System	17
CONVENTIONAL PIPE WORK SYSTEMS	18
Pumped Central Heating hot water circuit with gravity	18
Fully Pumped Central Heating hot water circuit	19
COMMISSIONING	20

GENERAL

INTRODUCTION

This booklet is to be read in conjunction with the installation and use instruction supplied with Redfyre solid fuel central heating boilers PM301, and is intended to give supplementary guidance regarding the safe and effective methods of linking other heating appliances to the Solid Fuel appliances

DUAL FUEL 'LINK UP' PIPE WORK SYSTEMS

A convenient way to install a solid fuel burning central heating boiler is to 'LINK' it with another boiler capable of burning another fuel e.g. gas or oil. This can dramatically reduce fuel bills whilst maintaining the convenience of a conventionally fuelled boiler.

The whole system can be linked to other alternative fuels such as solar heating to help reduce heating costs.

This is a specialised activity and must only be undertaken by qualified and experienced heating engineers. A poorly set up link system will not deliver the energy savings and may also be dangerous.

These instructions give general advice and suggestions regarding 'link up' technology but each system needs to be individually designed by a competent and trained engineer.

COMMON FAULTS WHEN DESIGNING AND FITTING A LINK UP SYSTEM

The process of linking two appliances into one system can be simple if all of the design parameters are under control, for example a new system.

Existing systems have many fixed parameters that will complicate the process.

Below are several common issues that effect the final system and explanations to solve the problems.

The paragraphs are split into three sections; Safety, Performance and Efficiency.

1. SAFETY

Open Vent

It is extremely dangerous to have an installation with a vent from the solid fuel appliance that can be closed off.

Ensured that there is an un-valved route from the solid fuel appliance flow tapping to the open vent on the system.

Manual switch between boilers

Do not design the system to allow the user to close the controls or valves or manually swap between boilers. It makes it possible for the solid fuel boiler to be lit when it should not be.

Incorrect motorised valves

Motorised valves used in a solid fuel system should normally be open so in the event of a power cut there is a route for the heat to dissipate via gravity circulation.

Incorrect Feed and expansion components

In a solid fuel heating system the Feed and expansion components should be able to withstand temperatures of 110°C and should preferably be a galvanised tank.

The float valve should be copper and the overflow pipe must be 22mm copper.

Incorrect link with sealed system boilers

Do not connect a solid fuel boiler directly to a sealed system. There must always be an interface between the sealed part of any system and the open vented part for the solid fuel appliance.

In the diagrams shown, this is usually a thermal store but a plate heat exchanger or similar can be used instead.

Over sizing the boiler and not providing adequate heat release on the heating circuit (or having too many TRV's) can result in the system boiling.

2. PERFORMANCE

Manual switch between boilers

It should be possible for both appliances to be used at the same time. The automatic boiler should provide any additional heat required when the solid fuel appliance is in operation.

The system must not prevent the use of any one appliance e.g by restricting the valves.

Insufficient circulation from solid fuel

It is common for the solid fuel appliance to be installed with only gravity circulation from the appliance into the system. This is a suitable method for boiler outputs up to 4.0 kW with 28mm primary flow and return pipes and 8.0 kW with 32mm flow and return pipes. Take care designing this type of system to ensure adequate vertical head for the horizontal distance between the appliance and the link point.

Above 8kW or with smaller pipes a pump must be used. This may require the use of a pump bypass to prevent the pump and isolating valves from restricting the cold feed or vent.

Circulation through unused boiler

If the link up is not at a neutral point or via an indirect link then the heated water from the appliance in use could pass through the idle appliance.

If this happens then there will be a large heat loss through the unused boiler resulting in reduced heat to the system, greatly increasing running costs.

Poor survey of existing system

If linking to an existing heating system the most common cause of problems is that the survey of the system did not find existing faults.

GENERAL

The link between the two systems must be at a point where the pipe sizing will not adversely effect the operation.

Use an experienced and qualified heating engineer.

Incorrectly sized solid fuel appliance

The sizing of the appliance is critical to the best operation of the system. Other issues that affect the choice are:

- Type of fuel to be used
- The balance between the room and the boiler outputs
- The output to room relating to the heat requirement of the room
- The overall load on the system and the solid fuel boiler output
- What is the likely usage pattern (continuous, intermittent or occasional?)
- A common problem is having a boiler output from the solid fuel appliance that is too large for the system, resulting in a regular overheat bringing on the radiators

Incorrect pipe sizing

If the size of the pipe connecting the appliance to the system is incorrect then there is a poor heat delivery to the system.

If it is too large it can result in a gravity circulation in the system when it is not required.

Poor gravity circuit design

If the system is for a small solid fuel boiler and it is designed to work off a gravity circulation to a thermal store or neutraliser, take care about the temperature the store can reach when heated by the gas or oil appliance.

Once the store reaches 80 degrees then the gravity circulation from the solid fuel appliance will stop and the water in the store could boil.

Get advice from the installer on the best way to use the controls.

Incorrect control location (room stats)

Using TRV's on the radiators of a system with a solid fuel boiler linked in can cause overheating. Note: If a heat leak radiator is used it can get very hot and should be a low surface temperature type or not be in a room used by young children. A room thermostat located by a heat leak radiator can result in an early shut down of the heating. Fitting the thermostat in the same room as a TRV can cause the heating to continue operating when the rest of the property is up to temperature.

3. INEFFICIENCY

Inefficient existing boiler

Linking a new solid fuel boiler to a system with an inefficient gas or oil boiler is a false economy.

Lack of adequate control

The linking of a solid fuel appliance to a system with inadequate controls will result in excessive fuel usage for both types of boiler. The time and temperature control of the system must be considered, as should the temperature of the water delivered to the taps

Poor balance between room and boiler output

If the solid fuel appliance has a poor balance between the room and boiler output for the property it can make the heating come on when it is not required or the room being far too hot before the solid fuel can contribute sufficiently to the heating.

Insufficient instruction on system use / controls

A cause of high fuel usage is not fully understanding the system and using the controls incorrectly.

This is even more important when there are two boilers to operate.

HEATING SYSTEM

1. General

The following diagrams shows various ways of fitting your Refyre Solid Fuel boiler stove to other heating appliances such as:

- Gas or oil boilers (open vented)
- Gas or oil boilers (sealed systems)
- Solar heating
- Combination boilers

These can be linked using either:

- Thermal store
- Conventional hot water cylinder
- Propriety link up systems

Below are details relating to the Refyre Solid Fuel boiler. Consult the manufacturers instructions for the other heating appliances and components before commencing work.

REDFYRE SOLID FUEL BOILER

This appliance gives out heat in two ways:

- Directly into the room in which it is fitted through convection and radiation
- Hot water to heat radiators and domestic hot water

The installation must comply with building regulations and use best practice advice.

2. Boiler Sizing

- 2.1 It is very important to determine the correct size of appliance for the house:
- Too big a boiler will run too hot and will not be efficient
 - Too small a boiler will not maintain the desired temperature
- 2.2 Size the boiler correctly by calculating the following heat loads:
- RADIATORS** - The amount of heat required to run the radiators efficiently
The correct size of radiator depends on the required temperature for the room, the room heat losses and the radiator manufacturer's guides.
- HOT WATER** - The amount of heat required to provide the desired amount of domestic hot water.
- LOSSES** – The amount of heat lost in pipe work - typically 10% of the combined radiators and hot water loads.
There are national guidelines for calculating these figures*.
- 2.3 Careful consideration must be given to the effect on where the appliance is fitted. It must be sized correctly for the heat load required and the size of the room. These heat outputs can be found in the Technical Specifications in the installation instructions supplied with the stove.

In the UK:

* See BS 5449:1

** See BS1566 Part 1 grade 3 minimum

- 2.4 All Refyre appliances have the option of being thermostatically controlled; the burning rate is adjusted to the demands of the connected heat load. If the radiators do not require heat then the thermostat will act to shut down the appliance and the direct heat output to the room where it is fitted will reduce (see heat output graph to show the ratio between direct heat output and water heat output). To prevent a situation where the room becomes too cold, fit a thermostatically controlled radiator as well as the appliance.

3. Hot Water Cylinder

- 3.1 It is recommended to link the Redfyre Solid Fuel boiler to other heating appliances using a thermal store, which should be sized according to the manufacturers instructions. However if using a conventional hot water system then this must be an indirect vented double feed type to meet national standards** and should have a minimum capacity of 117 litres. Houses with more than one bathroom or a separate shower will need a bigger tank.

The tank must be pre insulated and meet the current building regulations for domestic heating compliance requirements.

The water draw off pipes to the taps should be in a dead leg connection from the vent pipe.

4. Open Vent And Cold Feed System

- 4.1 This system must be fitted with a minimum of 22mm diameter open vent discharging into a heat resisting feed and expansion tank. When the heating system is up to operating temperature there must be at least 25mm air gap between the end of the pipe and the water level. The cistern tank should have an overflow with a minimum diameter of 22mm.

The cold feed must be a minimum 22mm and enter the system as the last connection on the common boiler return.

The open vent and cold feed must not be fitted with any valves, manual or automatic.

5. Heat Leak Radiator

- 5.1 A heat leak radiator must be fitted in the gravity circuit to dissipate any excess heat produced from the boiler when connected demand is low. The domestic hot water cylinder may not be able to disperse heat at all times due to modern insulation. This radiator is commonly fitted in the bathroom and should be rated at 2kW (6500 btu) or 10% of the total boiler output.

This radiator ensures that the appliance is not shut down completely for long periods resulting in the fire going out.

Fit the heat leak radiator in the gravity circuit using 22mm pipe reducing to 15mm for no more than 300mm before the radiator.

HEATING SYSTEM

Fit the radiator with two full way 'lock-shield' valves that are set in the fully open position and cannot be shut down. Use diagonal connections. Do not fit thermostatic valves or manually adjustable valves to the heat leak radiator.

6. Pump

- 6.1 Where a pump is fitted into the circuit it should be adjustable so that the flow can match the system requirements. Fit isolation valves to enable removal for servicing. The pump must have at least 1.5 meters of static head.

7. Electrical Supply

- 7.1 Electrical connections must meet the requirements of national Building Regulations* and standards**, along with any European, local regulations and working practices that may apply. Should conflict occur between these instructions and these regulations then the regulations must be followed.

The connection to the mains supply should allow complete electrical isolation and only serve the heating circuit pump.

All water connections should be completed by a competent person to meet the requirements of local water authority by-laws.

PIPE WORK SYSTEMS

All pipe work must be able to operate at above 100 degrees Celsius. Any pipe work installed in an exposed position e.g. loft space must have provision to prevent freezing.

Ensure the pipe work system has sufficient drain points to enable the complete removal of water for the purposes of servicing.

8. Gravity Pipe Circuit

- 8.1 To prevent the risk of boiling it is essential to arrange the pipe work and position the hot water cylinder and heat leak radiator so that gravity circulation can take place when the pump is not running. Position the cylinder and the radiator vertically above the boiler with sufficient height to encourage gravity flow.
- 8.2 Horizontal pipe work in a gravity system must have an incline of at least 5mm in every 1000mm and a minimum diameter of 28mm. Vertical pipe must have a minimum diameter of 22mm.
- 8.3 Any motorised valves fitted in this circuit must return to the fully open position when the power is interrupted.

OPEN SYSTEM PIPE WORK LAYOUT

Link Up of Stovax Solid fuel high output boiler to an OPEN VENTED gas or oil central heating boiler using a Thermal store.
This system is most appropriate for new installations where there is enough space for the thermal store.

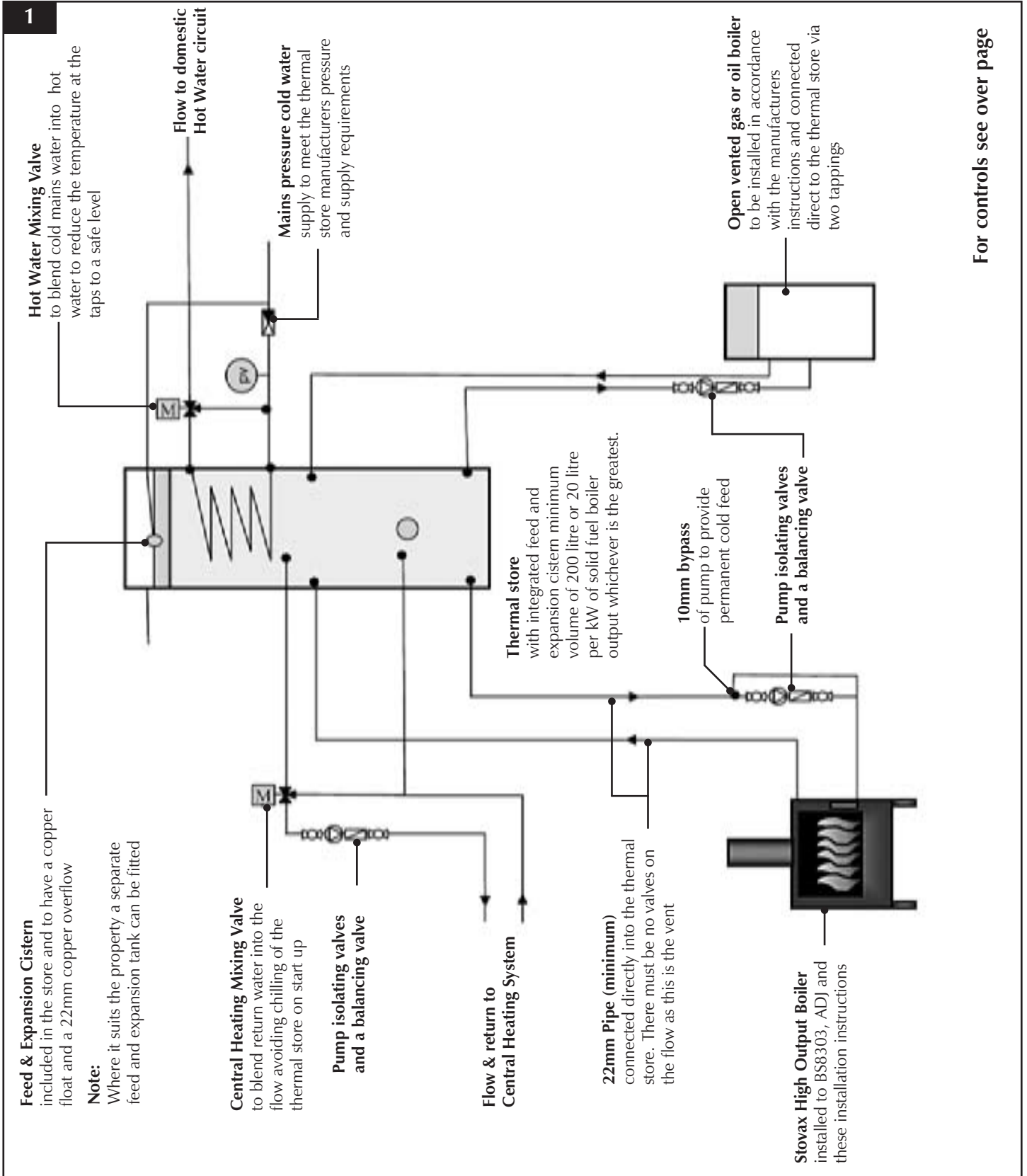

OPEN SYSTEM CONTROLS

Link Up of Stovax Solid fuel high output boiler to an OPEN VENTED gas or oil central heating boiler using a Thermal store.

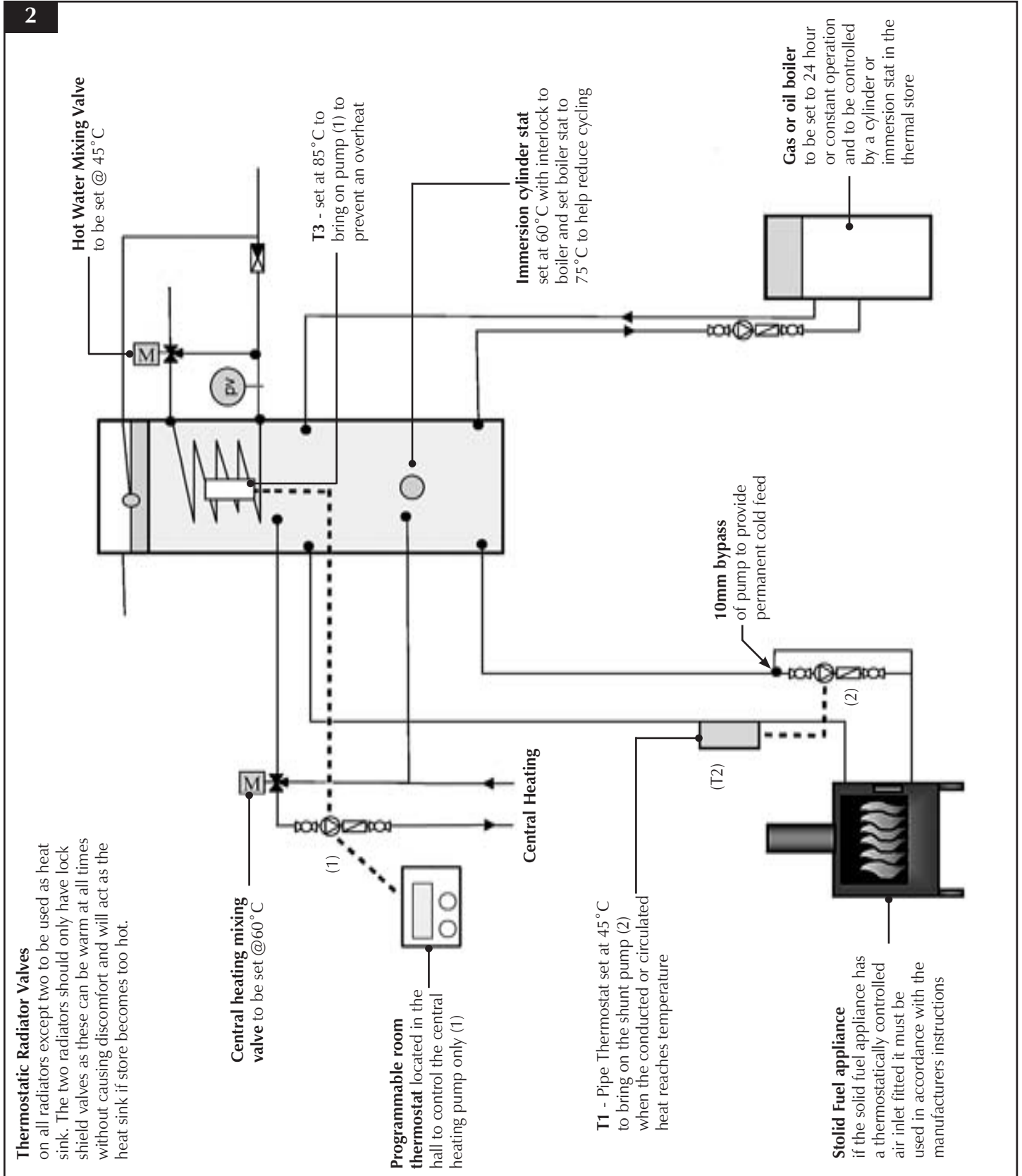

OPEN SYSTEM PIPE WORK AND CONTROLS LAYOUT

Link Up of Stovax Solid fuel high output boiler to an OPEN VENTED gas or oil central heating boiler where a Thermal store cannot be fitted of adequate size.

3

Feed & Expansion Cistern

to have a copper float and a 22mm copper overflow

Notes

2) The layout has been used to show that a separate feed and expansion cistern can be used where this suits the property layout or boiler and radiator locations

Heat Sink Radiator

Self venting. Valves to be full way lock shield radiator valves

Notes

1) The heat sink radiator(s) should be at least 25% of the solid fuel appliance maximum output (required when the optimum thermal store size can not be accommodated)

(AAV) - Automatic air vent

(V1) - normally open two port

(T3) - set at 85°C to bring on Central Heating Pump (1) in event of an over heat

(T1) - set at 65°C to bring on pump (2) to distribute heat from solid fuel stove to the thermal store

Stovax High Output Boiler

installed to BS8303, ADJ and these installation instructions

10mm bypass of pump to provide permanent cold feed

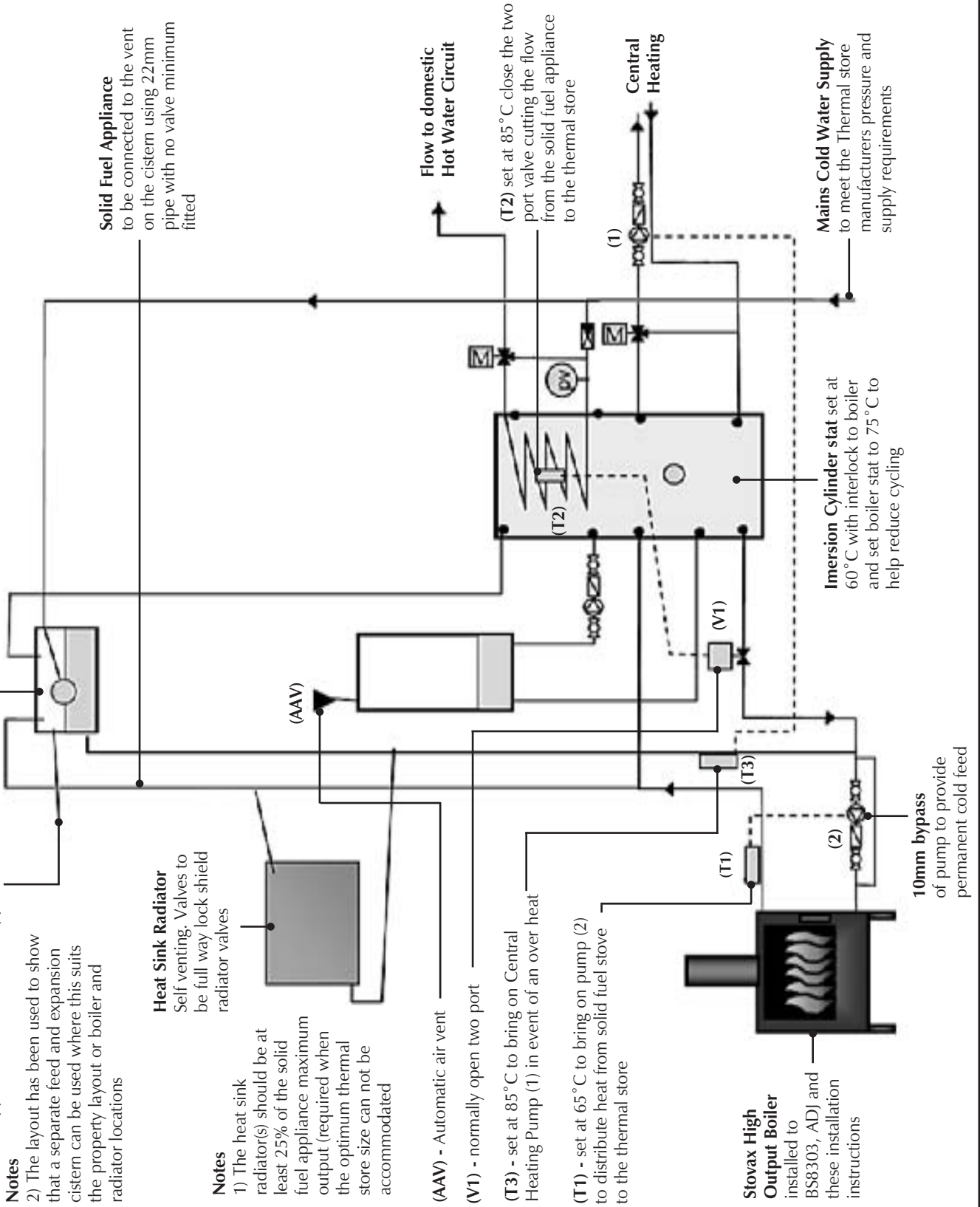

SOLAR PIPE WORK AND CONTROLS LAYOUT

Link Up of Stovax Solid fuel high output boiler to an OPEN VENTED gas or oil central heating boiler using a Thermal store AND SOLAR.

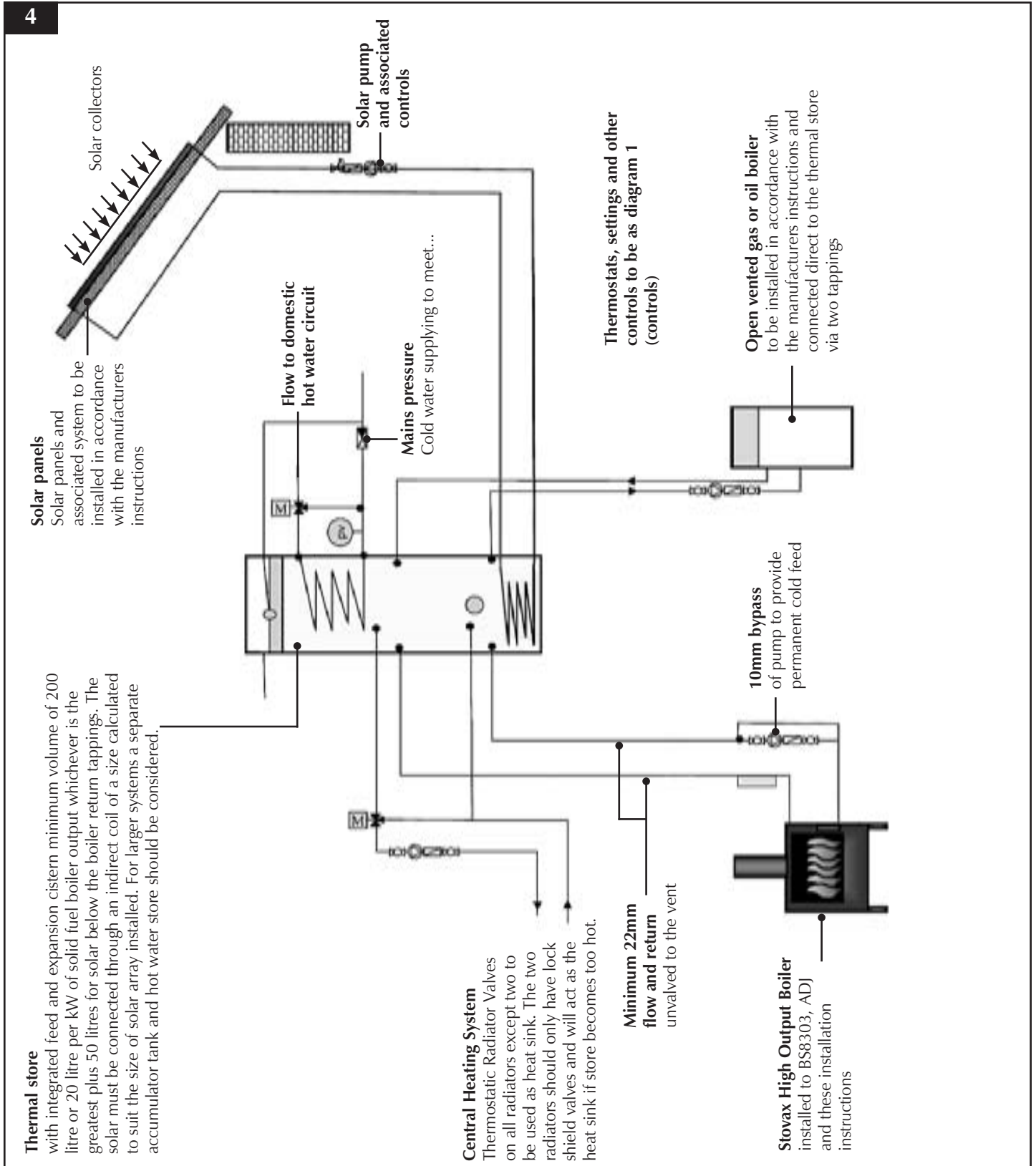

SEALED SYSTEMS PIPE WORK LAYOUT

Link Up of Stovax Solid fuel high output boiler to A SEALED SYSTEM gas or oil central heating COMBI boiler using a Thermal store.

5

Sealed system condensing combination boiler
to be installed in accordance with the manufacturers instructions, connected indirectly to the Thermal Store and with the hot water supply being preheated by the Thermal Store.

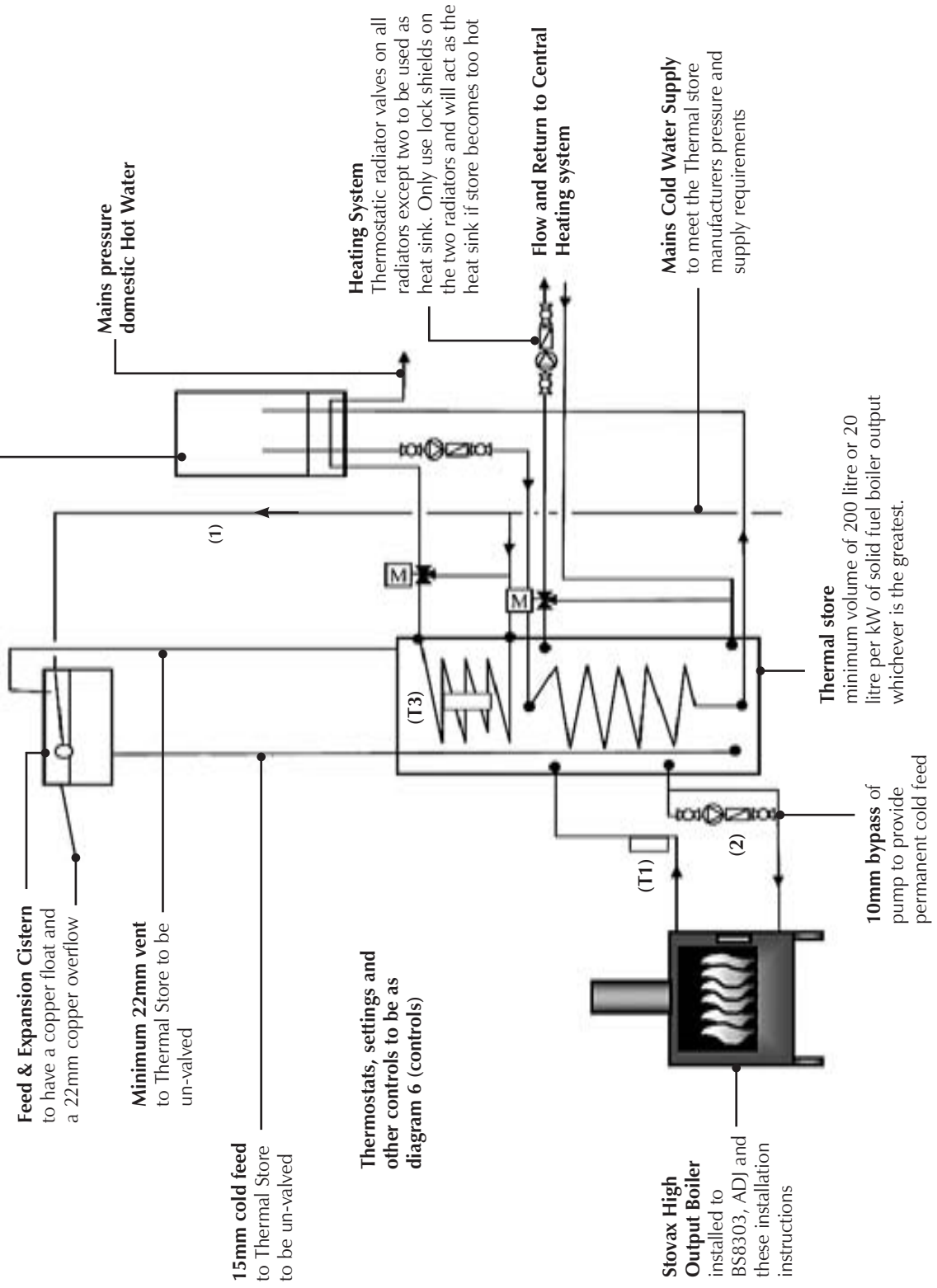

SEALED SYSTEMS CONTROLS

Link Up of Stovax Solid fuel high output boiler to an OPEN VENTED gas or oil central heating boiler using a Thermal store and SEALED HEATING SYSTEM.

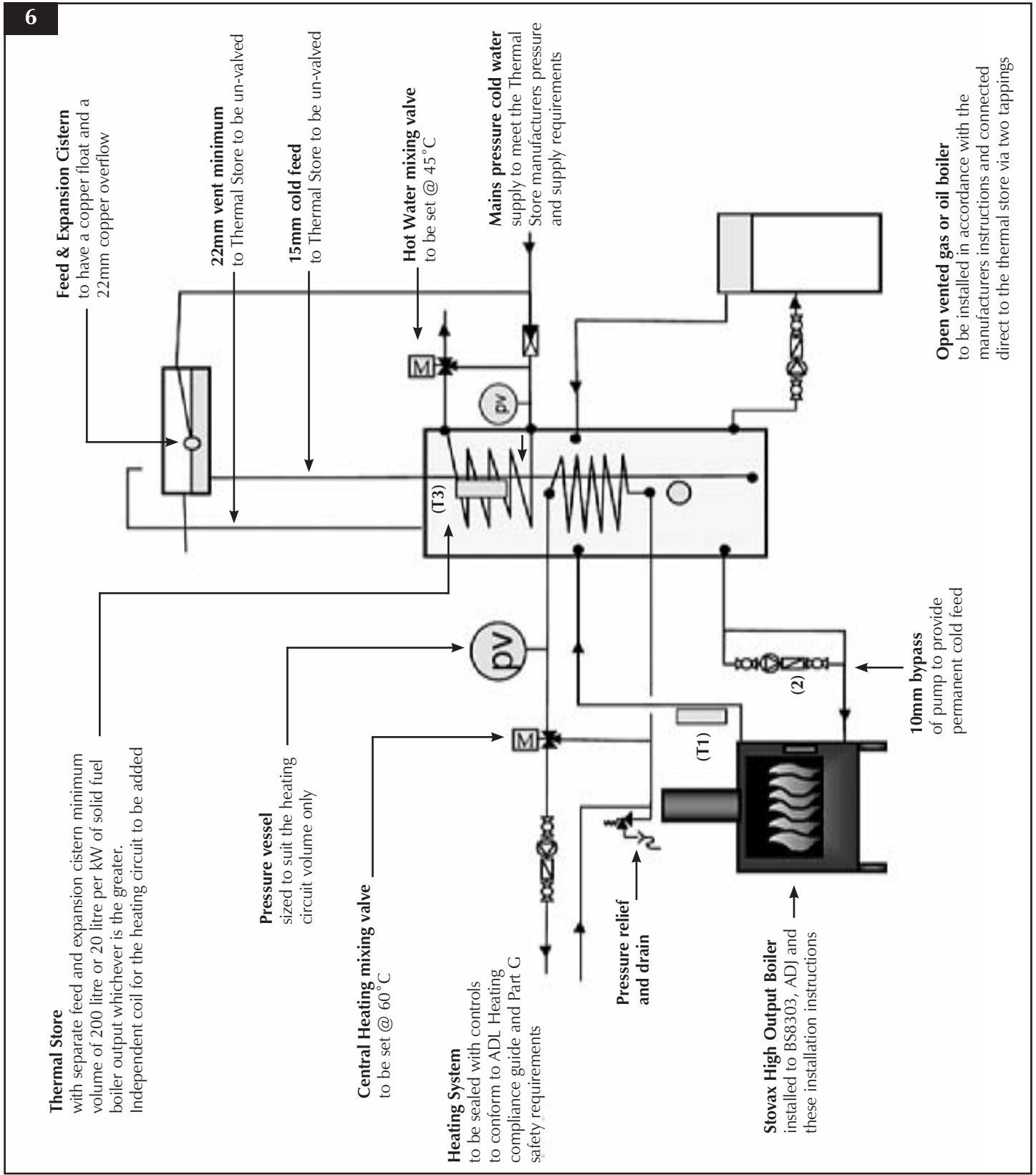

PROPRIETY DEVICES

Link Up of Stovax Solid fuel high output boiler to A SEALED SYSTEM gas or oil central heating COMBI boiler using a NEUTRALISER Eg: Dunsley.

7

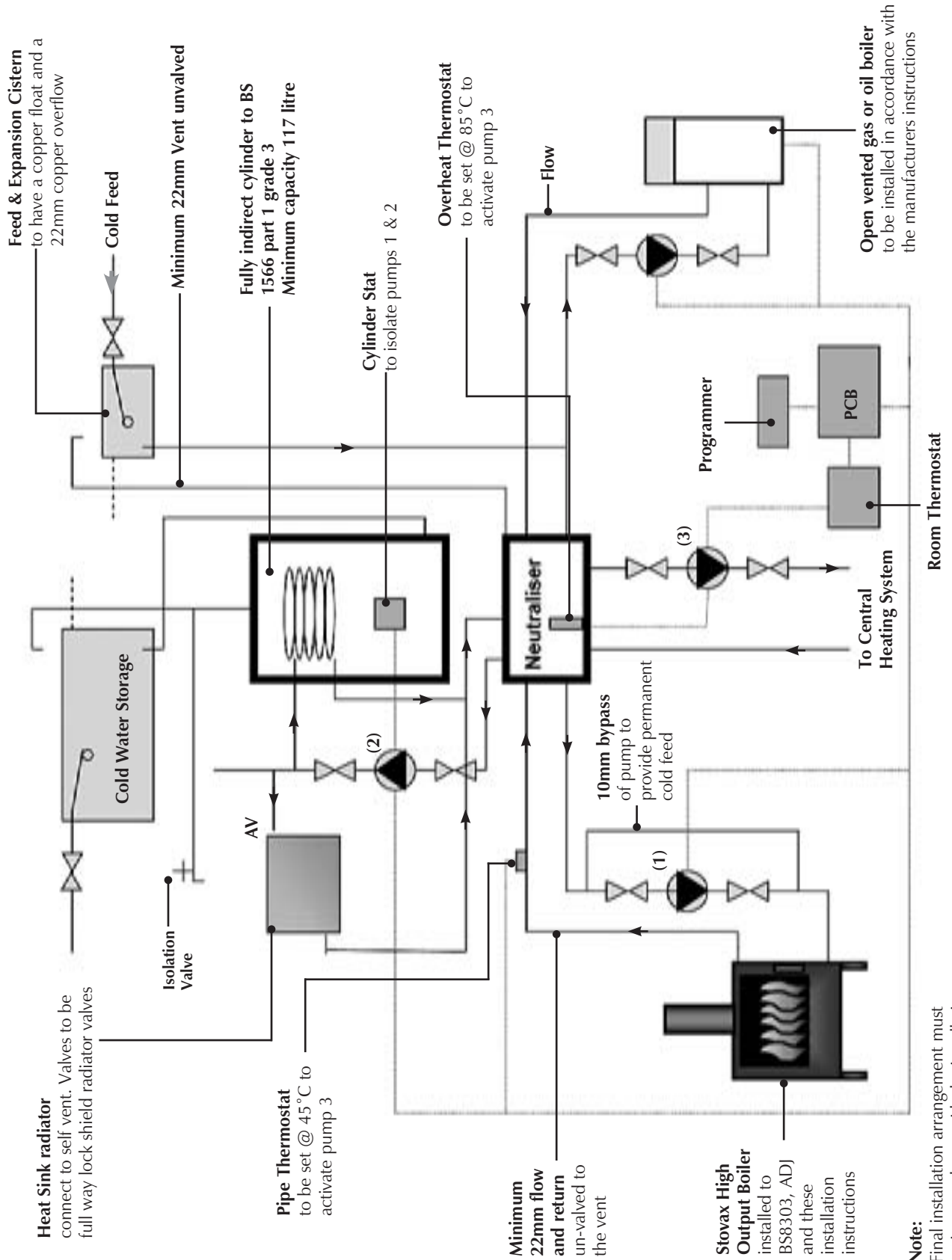

Note: Final installation arrangement must be in accordance with the installation instructions supplied with the Neutraliser

PROPRIETY DEVICES

Link Up of Stovax Solid fuel high output boiler to an OPEN VENTED gas or oil central heating boiler using a HEATING INNOVATIONS H2 PANEL.

9

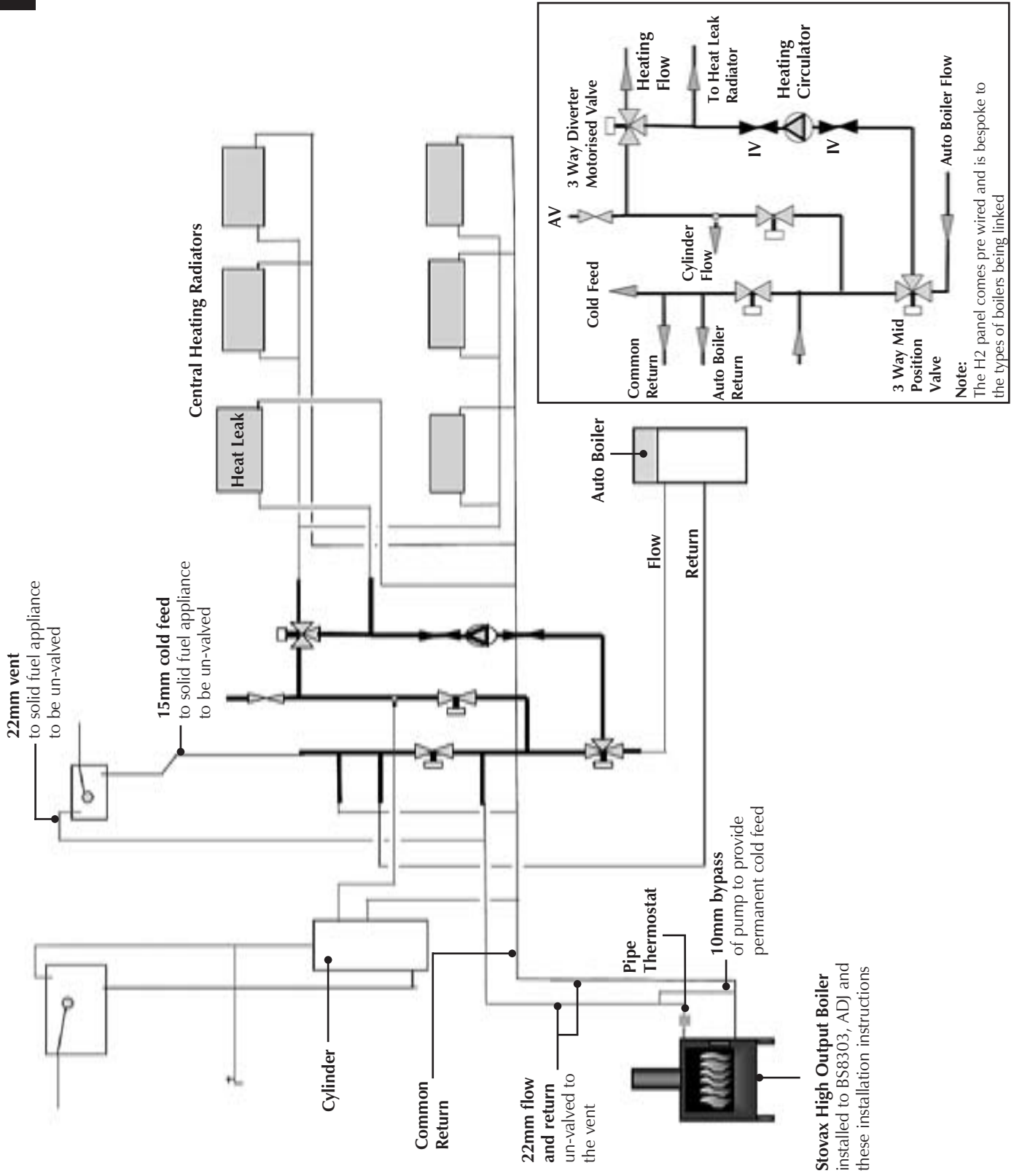

CONTROL SYSTEMS

1. GENERAL HEATING SYSTEM CONTROLS

CONTROLS GENERAL

- 1.1 The controls fitted to the system will provide two functions:
 - To control the comfort level in the house
 - To maintain safety in the event of misuse or mechanical failure

COMFORT CONTROLS

- 1.2 This primarily consists of a time clock wired into the pump. The pump is switched on when heat is required and when it is not, the pump is switched off.

The time clock when combined with a room thermostat and or thermostatic radiator valves enhances the comfort levels in the house.

Some room thermostats combine the function with the time clock and can be programmed to reduce the room temperature rather than turning the system off. This is effective in not allowing the rooms to become too cold and speeding up recovery time.

- 1.3 The hot water cylinder can also be fitted with a thermostatic valve which turns off the flow when the cylinder has reached the desired temperature (This is now a requirement for new systems) but the heat leak radiator will have to be bigger to cope with the extra load when the tank is isolated.

SAFETY CONTROLS

- 1.4 This primarily consists of a high limit thermostat fitted to the gravity flow pipe set at 80 degrees Celsius, this thermostat should be connected to the pump so that the pump is turned on if the temperature exceeds 80 degrees. This will prevent accidental boiling in the gravity circuit.
- 1.5 It is also recommended to fit a low limit thermostat on the gravity return set at 45 degrees Celsius, this thermostat will turn the pump off if the return temperature falls below 45 degrees. This will prevent corrosion and condensation within the stove.‡

NOTE – Further information on solid fuel central heating systems can be found in the HETAS engineers training manual.

2. CONTROLS FOR LINK SYSTEMS

The controls for a link system come under a number of headings: Safety, Efficiency and Comfort.

1. SAFETY

The safety controls help prevent the system from boiling. Remember that the controls put on a system that has a solid fuel appliance installed must be totally safe in the event of the solid fuel appliance over firing. This requires an open vent and separate cold feed with no valves from the appliance to the feed and expansion cistern.

Over heat stat

This activates the pump in the heating system to ensure the water in the solid fuel appliance does not reach boiling point by relying on a number of radiators that can be used to dissipate the excess heat.

This is a pipe thermostat that is normally placed on the flow from the solid fuel appliance, is set at approximately 85 ° C, and brings on the central heating pump to over ride other controls.

Note: If the recommended method of a thermal store is being used as the interface, then fit the overheat stat to the thermal store.

Hot water temperature

Solid fuel often raises the temperature of any stored hot water above a safe level for the outlet at the taps.

A thermal store should have a mixing valve on the hot water outlet set between 38 and 45°C.

If not the case then install mixing valves at the point of use.

Frost thermostat

Lighting a solid fuel fire when any part of the system is frozen can result in an explosion due to over pressurisation. Since these systems have a second heat source that can be automatically started, we would advise the fitting of a frost thermostat.

Pressure relief valve

Water by laws often require the fitting of a pressure relief valve for the same reason given above. Note: This should be as close as possible to the solid fuel appliance but care must be taken when considering the discharge path.

CONTROL SYSTEMS

2. COMFORT

There is minimum level of control required for any heating system that is new or has had a major change. This is regulatory under the Approved Document L1 of the Building Regulations domestic heating compliance guide. This must be followed but a basic guide is given below.

Time of heating

The space heating must be time controlled so that it is only operated for the amount of time required to maintain a comfortable temperature.

If the thermal store is being used it can be combined with a programmable room thermostat which will simplify the control layout.

Temperature of accommodation

The use of a combination of room thermostat and /or thermostatic radiator valves (TRV's) is required. When a solid fuel appliance is included in the system it is recommended that there is part of the system that does not have TRV's fitted. When the overheat thermostat activates some radiators will be allowed to dissipate the excess heat. The recommended uncontrolled radiator output is at least 25% of the solid fuel appliances boiler output. These radiators can get very hot and consideration should be given to using low surface temperature radiators.

Variable head pump

Use a variable head pump for the main heating circuit to enable the boilers or thermal store to operate more efficiently as the TRV's close and open. The pump will automatically adjust the water delivery around the system based on the resistance in the circuit to ensure the optimum flow through the store or boiler.

Zoning

The Domestic Heating Compliance guide requires that any heating system in a property be zoned. If the property floor area is less than 150m² then this can be done by the use of TRV's as mentioned above.

For properties with larger floor areas the zones must have separate time and temperature controls per zone. This requires the hydraulic separation of the zones either by valves or by a low loss header and separate pumps per zone. The latter system is easier and enables the use of a programmable room thermostat per zone.

3. EFFICIENCY

The basic controls above can be supplemented by the use of controls that can increase the efficiency of the system or reduce the energy usage.

When a system is installed and used there are various repetitive conditions that a system like this can "learn" from, if the temperature is increasing during the day the heat input to the property needs to be less as time goes on, also there may be some solar or other gains that can be predicted. A weather compensation system predicts these occurrences and reduces or increases the heat delivered to meet the changing needs. Most people find this results in a more even temperature in the property during the day.

The way a majority of systems work is to have a variable temperature mixing valve on the outlet of the appliance or thermal store and the flow temperature is altered based on the differential between the outside and inside temperatures.

This type of system will be designed to meet the properties needs and should be specified from the manufacturer. Note these types of systems will often replace many, if not all of the comfort and efficiency controls listed above.

CONVENTIONAL (NON LINKED) PIPEWORK LAYOUT

4. Pipe work diagrams

- 4.1 See next page for a typical layout of a pumped central heating and gravity hot water circuit when not linked up to another heating appliance.

5. Pump Assisted Central Heating

- 5.1 The most common arrangement is to have a pumped central heating circuit combined with a gravity hot water circuit. This arrangement requires careful balancing of the two in order to avoid the gravity circuit being starved when the pump is running.

To overcome this problem it is common practice to fit an injector tee where the pumped central heating return re-joins the gravity return from the hot water cylinder. This injector tee induces a much stronger gravity flow when the pump runs.

- 5.2 Only use proprietary injector tees, homemade ones are difficult to get right.

6. Fully Pumped System

- 6.1 In many installations (especially new build) a fully pumped system is the best choice to give increased control.

WARNING - To prevent the risk of boiling it is essential to arrange the pipe work and position the hot water cylinder and heat leak radiator so that gravity circulation can take place when the pump is not running. Any motorised valves fitted in this circuit must return to the fully open position when the power is interrupted.

7. Sealed (Pressurised) System

- 7.1 Do not fit this appliance to sealed or pressurised systems or an unvented hot water cylinder.

CONVENTIONAL PIPE WORK SYSTEMS

GRAVITY

See below typical layout of a pumped central heating hot water circuit with gravity.

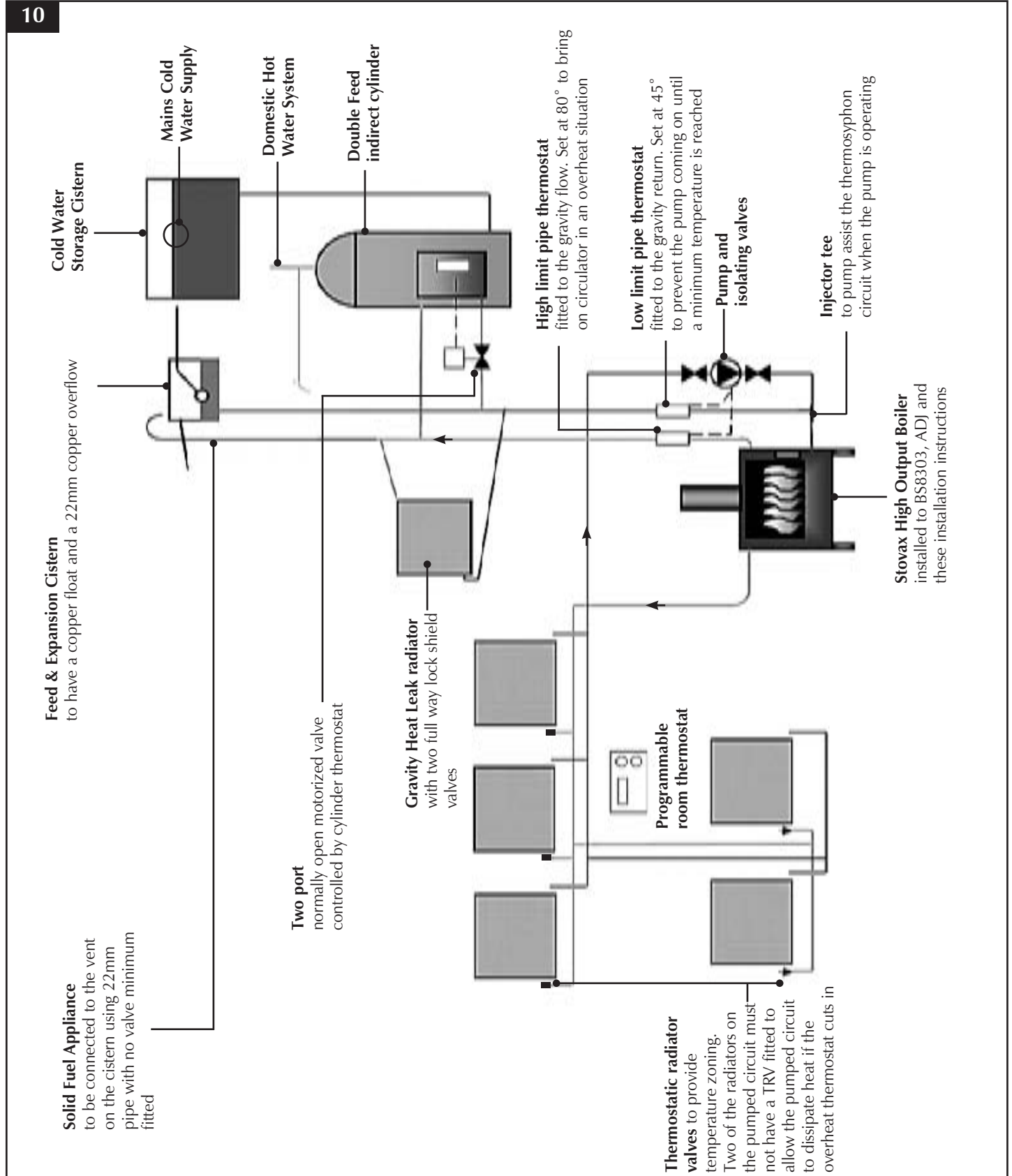

CONVENTIONAL PIPE WORK SYSTEMS

PUMPED

See below typical layout of a fully pumped central heating and hot water circuit.

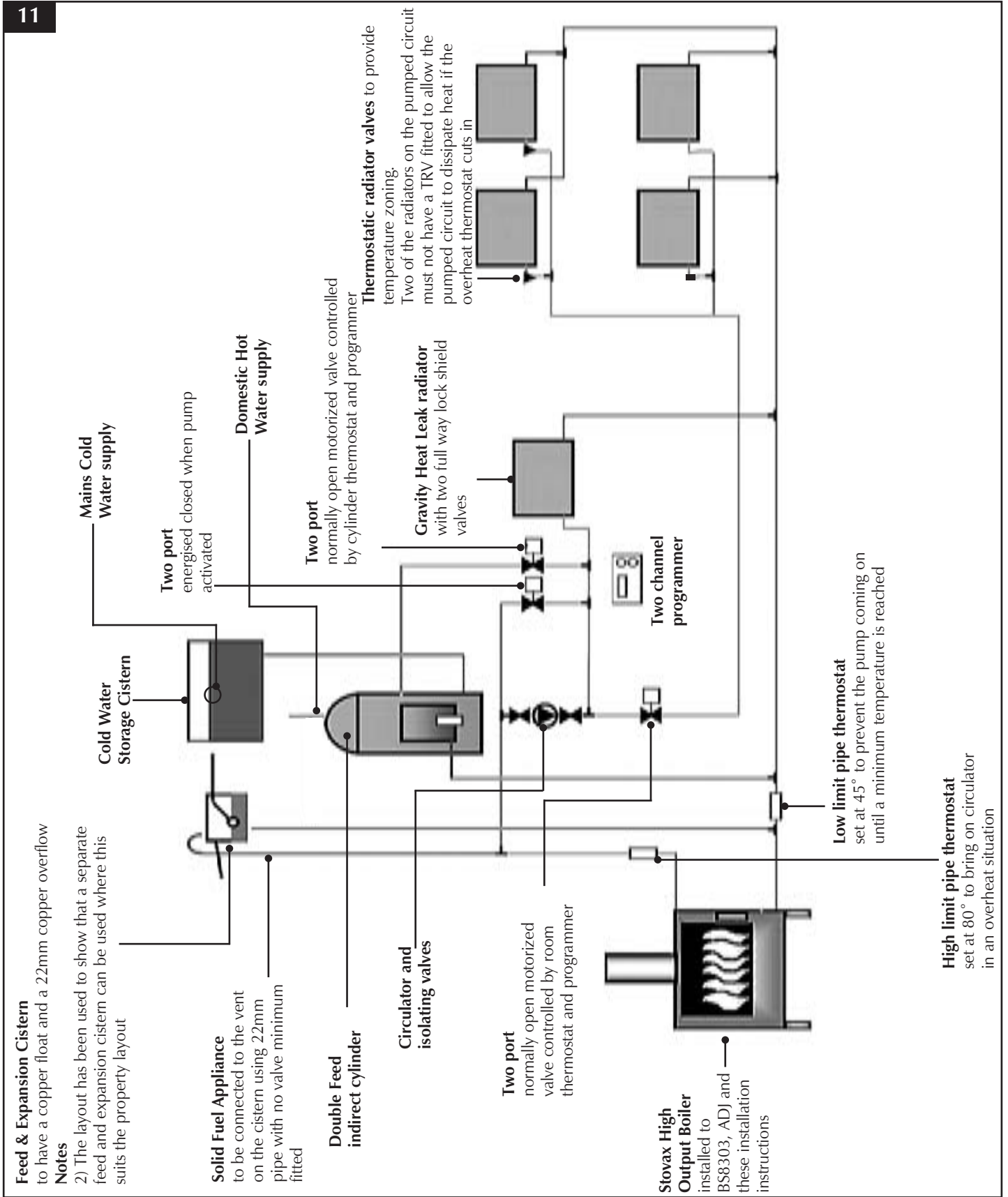

COMMISSIONING

COMMISSIONING

1.1 To commission:

- Replace the log retainer
- Check the door alignment and catch operation, adjust if required, see Installation Section 6. Adjusting Door hinges
- Check the soundness of door seals, castings and joints
- Check the operation of the air controls

1.2 Now carry out a final smoke draw test:

- First warming the flue with a blowlamp, or similar, for about 10 minutes
 - Place a smoke pellet on the centre of the grate, with the air controls open
 - Close the door
- Smoke should now be drawn up the flue and be seen to exit from the flue terminal
- Complete test with all doors and windows closed in the room where the appliance is fitted
 - If there are any extractor fans in adjacent rooms, the test must be repeated with the fans running on maximum and interconnecting doors open
 - Check the effect of ceiling fans during the test

If the test fails, re-check the suitability of the flue system and ventilation. An inadequate air supply to the room is potentially dangerous.

- Light the appliance and slowly increase the temperature to operating levels
- Ensure no combustion products enter the room
- Open the main fire door when the appliance reaches operating condition and carry out a spillage test with a smoke match or pellet around the door opening
- Run the system up to temperature:

BALANCING THE SYSTEM

It is essential to balance the central heating system in order to achieve an even heating performance across all of the radiators in the house. Balanced means each radiator having a 10 degree difference in temperature between the flow and the return, ideally 80 degrees flow and 70 degrees return.

Have the system running and adjust the appliance thermostat so that the flow temperature measured near the appliance is approximately 80 degrees. Ensure that all valves including lock-shield valves are in the fully open position and the pump is at its estimated correct speed. If there are thermostatic radiator valves, have these on maximum setting and ensure that they do not activate (open windows).

Ensure that the radiators have been bled of air.

Write down the return temperature of each radiator in turn and its difference to the flow temperature at the appliance, make sure that the flow temperature remains constant.

The radiator with the greatest difference (the index radiator) and any other radiator within 1 degree should be left with

the lock-shield fully open. The remainder of the lock-shield valves should be closed to about 1/3 open. Leave the system to stabilise, this could take some time.

When the system has stabilised, write down the new difference between the flow and return temperatures and any which differ from the index radiator by more than 1 degree will need further adjustment, some valves will have been closed too much and others not enough, usually the adjustments need to be only a fraction of a turn at a time. Leave sufficient time for the system to stabilise after each adjustment.

When the radiator temperatures are starting to become consistent, but before final adjustments, the index radiator needs to be considered, if the return temperature of this radiator is not near 70 degrees then the pump will need to be adjusted to either provide more (to increase the temperature) or less flow to decrease the temperature. Again sufficient time will need to be left to allow the system to stabilise after adjusting the pump speed.

When the radiator flow and return temperatures are about right, the final adjustments can be made and the lock-shield covers replaced.

Experience in knowing how far to shut down a valve to get the desired change in flow and return temperature and knowing how long to wait for the system to stabilise takes a little time and practice.

1.3 If excessive spillage occurs:

- Allow the appliance to cool and re-check the flue system and ventilation

1.7 Finally:

- **Explain the safe operation of the appliance and the use of the controls to the user and the importance of only using suitable fuels**

- **All open flued appliances can be affected by temporary atmospheric conditions which may allow fumes to enter the house. Because of this it is recommended that an electronic carbon monoxide detector conforming to BSEN50291 be fitted and maintained.**

- **Explain the cleaning and routine maintenance requirements**

- **Explain the requirement to use a suitable fireguard when children, elderly or infirm persons are near the appliance**

- **Record dealer/supplier details and installer details in *Instructions***

- **Record serial number in page 3 of *Instructions***

This number is required when ordering spare parts and making warranty claims

- **Give the copy of the *Instructions* to the customer**



A division of Stovax Ltd

Stovax Ltd, Falcon Road, Sowton Industrial Estate, Exeter, Devon, England EX2 7LF

Tel: (01392) 474011 Fax: (01392) 219932 E-mail: info@stovax.com www.stovax.com